

SPECIFICATION

PARAMETER	METHOD / DEVICE
WEIGHT	Digital scale Axis (precision 0,01g)
HEIGHT	Gawis-OD Agr / Electronic altimeter (precision 0,01mm)
TOP LOAD	Top Load Agr / Digital Newton meter BFG N (0,1-500N)
DIAMETER	Gawis-OD Agr / Micrometer of 0,001mm precision, according to DIN 863
COMPONENTS	Gawis-OD Agr / Digital caliper of 0,01mm precision, according to DIN 862
MATERIAL DISTRIBUTION	Gawis-OD Agr / PTG5004 AGR
TOTAL CAPACITY AND FILLING HEIGHT	Combi Agr
HORIZONTAL AND VERTICAL ALIGNMENT	Gawis-OD Agr / Angle gauge, according to DIN 875/0 + Gap gauge (0,05-1,0mm) (max. 1,0mm/100mm)
STABILITY ON THE SURFACE	Flat marble slab + Gap gauge (0,05-1,0mm)
COLOUR	Spectrophotometer Ci5 (laser measurement) according to standard
TIGHTNESS	Vacuum chamber (underpressure of 600mbar during 180s.)
DROP TEST	Trap on 1,5m height
PRODUCT IMPLEMENTATIONS AND QUALITY ANALYSIS ARE PERFORMED WITH THE USE OF THE FOLLOWING DEVICES: Agr Gawis-OD, Top Load/Combi, PTG5004	

TECHNICAL DRAWING

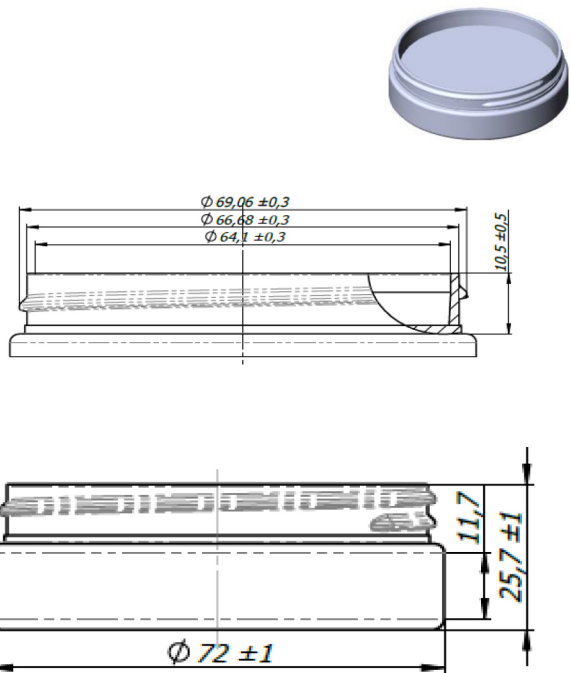

Capacity:	50 ml
Thread:	STC70-400
Material:	polyethylene terephthalate

Parameters	Given dimensions	Tolerance
Height (mm)	25,70	+/- 1,0
Diameter of base (mm)	72,00	+/- 1,0
Weight (g)	15,00	+/- 1,0
Total capacity (ml)	84,00	+/- 4,0
Distance to the cap (mm)	10,50	+/- 0,5
Outer diameter thread with a roll (mm)	69,06	+/- 0,3
Inner diameter of the hole (mm)	64,10	+/- 0,3
VERTICAL (max 1/100mm)	V	V
IT SHRINKS ON SURFACE SECONDARY	X	-
SHAPE CONFORMITY	V	-
STABILITY BASE BOTTLE	V	-

VISUAL PACKAGING

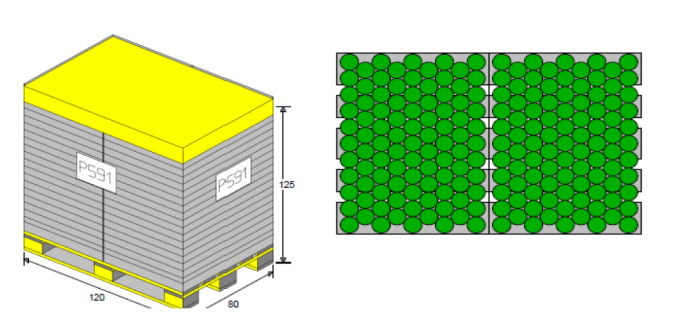

PACKAGING	
ON PALLET	7220
LAYERS	19
ON LAYER	2 x 190
PALLET HEIGHT	1250,00mm

We have implemented and certified Management System PN EN ISO 9001:2015, ISO 15378:2015, ISO 15593:2010