

HENKEL DMS 194349

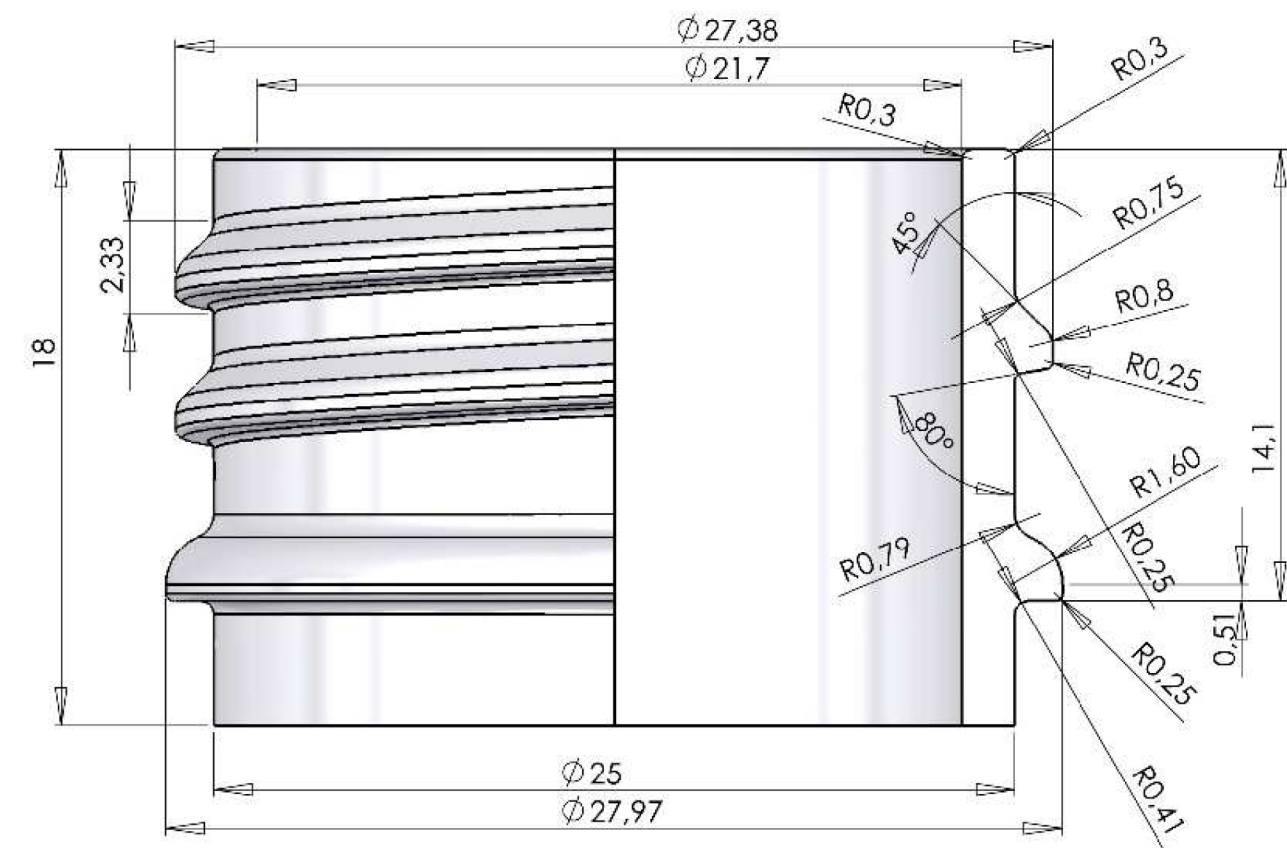
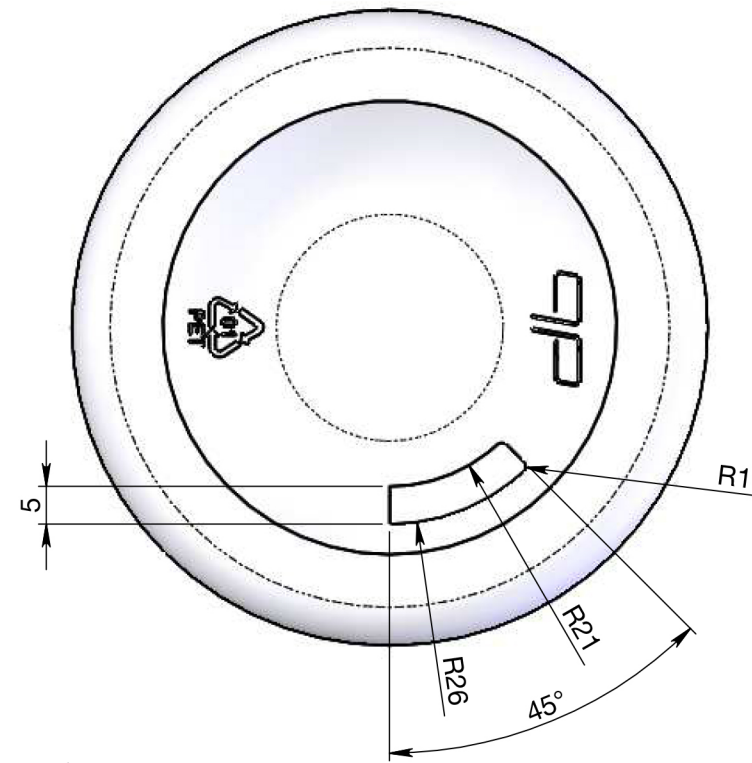
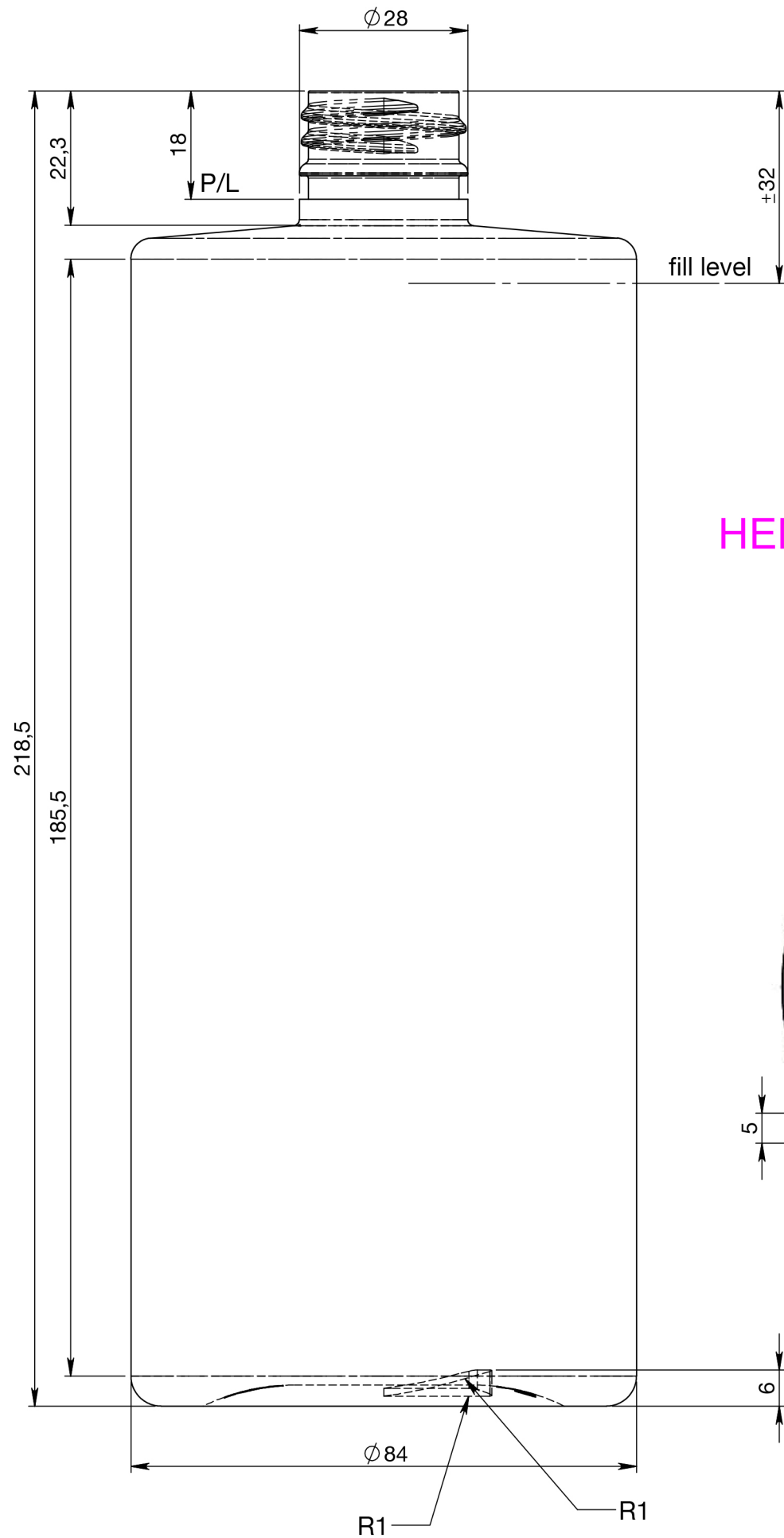

ART. NO.	4028-1000c0016	CUSTOMER	Standard	NOMINAL	1000 ml	FINAL
DWG NAME	2017261A002	NECK FINISH	28 SP410 (H18)	BRIMFULL	1048 ml	SCALE (front view) 1:1
DATE	27-12-2017	DESIGNER	BM	WEIGHT	45 g (± 1.0)	MATERIAL PET
TOLERANCES						All dimensions are in mm
Injection Moulded Dimensions						This document in design and detail is the property of PET Power B.V. and is not to be used or reproduced by unauthorized persons.
Blow Moulded Diameter						
Product Height						
TITLE						

28 SP410 1000 ml Sharp Cylindrical V2

ISSUE	DATE	CHANGE / STATUS	APPROVED BY	TOLERANCES
3.0	02-11-2018	Final	RvD	Injection Moulded Dimensions
0.3	17-05-2018	Skibaan bematen	BM	Blow Moulded Diameter
0.1	26-04-2018	Tentative	RvD	Product Height

Version: BD&T_2017 A3