

FLIP LIFTING FORCE (Kg)	
MINIMUM	MAXIMUM
1	2.5

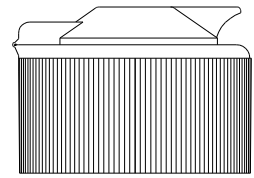

SCALA 1 : 1
SCALE

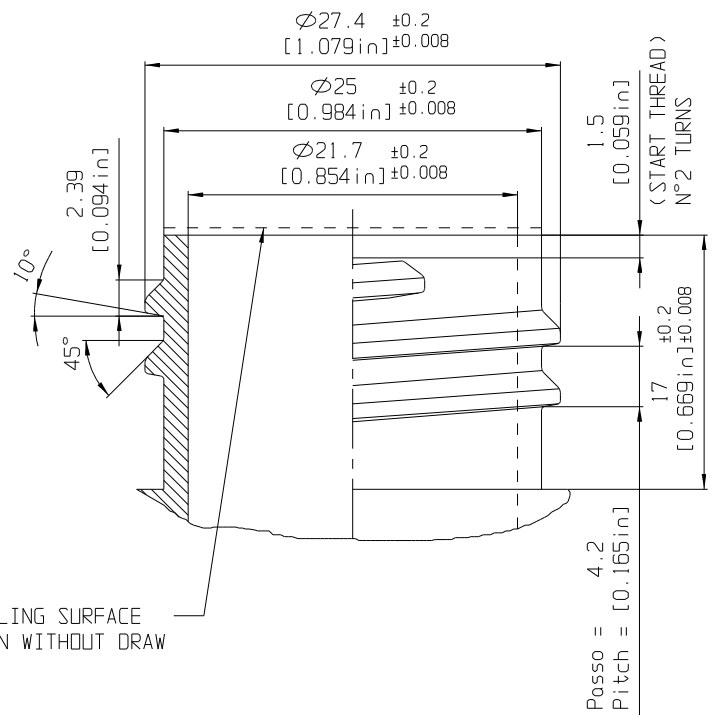
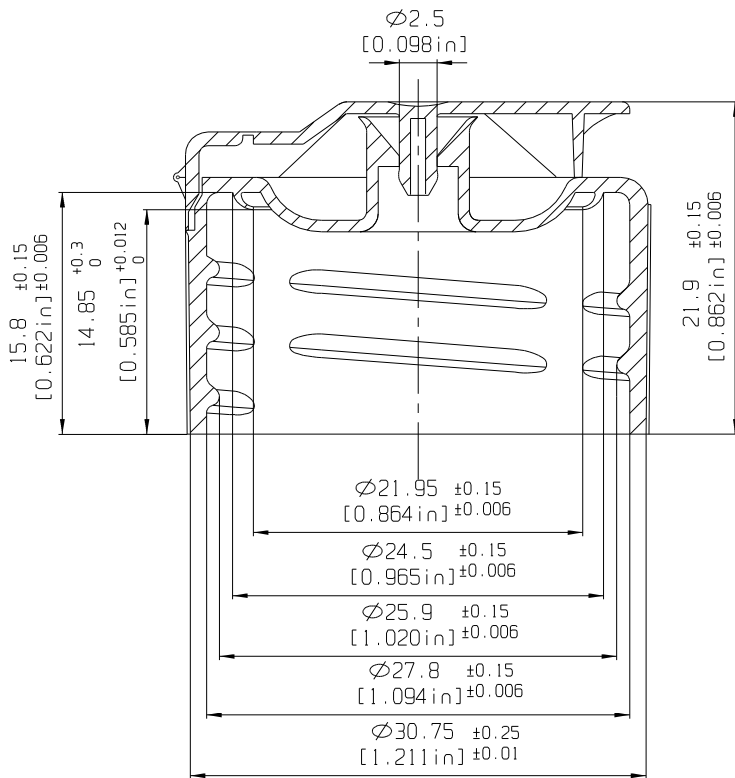
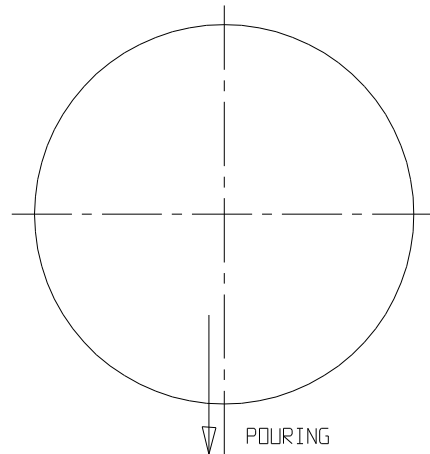

ALL QUOTES ARE EXPRESSED IN MM
(INCH)

G	UPDATED WEIGHT	ZR	05/10/2016
F	UPDATED DRAWING	ZR	22/09/2015
E	UPDATED MAXIMUM FLIP LIFTING FORCE	CANNONE F.	21/06/2012
D	ADDED TOLERANCE ON WEIGHT	L.P.	07/05/2008
N°	MODIFICA/REVISION	VERIFICA/VERIFY	DATA/DATE

THIS DRAWING IS PROPERTY OF		DENOMINAZIONE/DENOMINATION		ART./ PR.	
		LIGHT FLIP TOP		338/25	
		NECK STD SP 28/410 HOLE 2.5 mm (0.01 in)			
DIS. N°	338 25	MATERIALE	PP	PESO	3.3±0.2 gr
FILE		MATERIAL		SCALE	2:1
				DIS. TO	MG
				DRAWN BY	MG
				DATA	23/02/96
				DATE	

	TITLE:		
TECHNICAL SHEET	Code	Revision: 00	Page 1

1. MATERIAL SPECIFICATIONS

	Name	Material			
1	CAP	PPH			
2	Master batch	PP-PE			

2. SHAPE AND DIMENSIONS

3. NOTICE & RECOMMENDATION

Suggested torque to ensure correct closure:

8-15lb*in
0.9-1.7N*m
9-17Kg*cm

4. QUALITY SPECIFICATIONS

	ITEMS	QUALITY STANDARDS	TEST METHOD
1	Appearance	No abrasive cut, no dirty surfaces uniform colour tone, no breakage or damaging	Refer to approved samples
2	Materials	Refer to std pages	
3	Weight	Refer to drawing	
4	Dimensions	Refer to drawing	
5	Lid opening force	2.75±1.75Kg	use a dynamometer at \cong 50 mm/min rate
6	Hinge resistance	Rotation: 3lb*in [3.5Kg*cm]	- With the lid open at 180° use a torque tester
7	Leakage	No leakage detected after laid upside-down for 24 hours at room temp.	Coloured water filled in, close at 14 lb*in
8	Vacuum leakage	No leakage detected	Coloured water filled in Pressure -400mBar for 60sec

5. STORE INDICATION AND SHELF LIFE

1	The storage temperature should preferably be between 5°C and 25°C.
2	The relative humidity in the store room should be below 75%.
3	Protection from light, in particular rather strong sunlight and strong artificial light with a high ultra-violet content, unless the articles are packed in opaque containers
4	Storage rooms should not contain any equipment that is capable of generating ozone, such as mercury vapor lamps, high voltage electrical equipment, electric sparks or silent electrical discharges.

If the items are carefully stored as recommended above, their shelf life is generally two (2) years. Where there is any reason to think that storage conditions are less satisfactory than those recommended, representative samples from each batch should be tested before assembly the component.