

Product data sheet

Item number: **68555**
Item name: **Produce bag (HDPE) roll extra-strong clear 22+11 x 48 cm `5kg+` [200 pcs]**

Item

Length: 22 cm Material thickness: 9,5 µm
Width/diameter: 11 cm Color: transparent
Height: 48 cm Material 1: Polyethylene - high density
Weight: 2,5 g Material 2: Solvent (glue)
Customs nomenclature: 39232100
Core Ø 25 mm.



Package

Length: 22 cm No. of pieces in a package: 200 pcs
Width/diameter: 8 cm Weight: 530 g
LOT: YES
EAN:

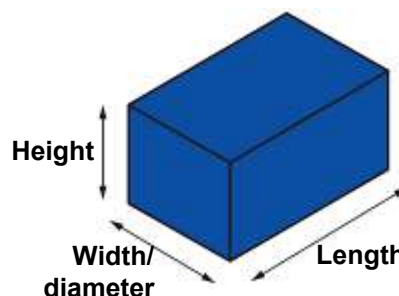

Packaging material: Polyethylene - high density (HDPE)
Packaging type: Bag

Group packaging

Packaging material: Polyethylene - low density (LDPE)

16 pkg.

Carton

Length: 40 cm No. of packages in a carton: 20 pkg.
Width/diameter: 32 cm No. of pieces in a carton: 4000 pcs
Height: 25 cm Weight: 11,17 kg
Volume: 0,03 m3
EAN: 4052509685550
LOT: YES

No. of packages in a carton:

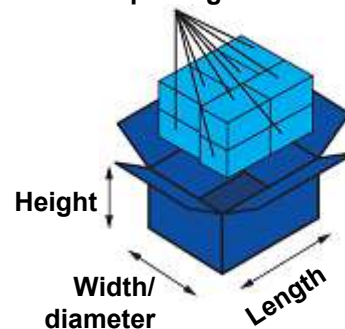

Packaging material: Paper - corrugated cardboard (PAP)
Packaging type: Corrugated box - extra strong

Pallet

Layer height: 25 cm Height: 165 cm
Number of layers: 6 Weight: 422 kg
No. of cartons on the layer: 6 No. of cartons on the pallet: 36 ctn
No. of packages on the pallet: 720 pkg.
No. of pieces on the pallet: 144000 pcs

No. of cartons on the layer:

